

W32L100-PTA3

32" Multi-Touch Chassis Display



KEY FEATURES

- 32" 1920 x 1080 with P-CAP touchscreen
- Bottom side keys x 5
- Fanless and Ventless design, Easy-to-Clean
- Support VGA, HDMI (Optional) signal input
- Front IP65



SPECIFICATIONS

Display	
Resolution	1920x1080
Contrast Ratio	4000:1
Display Color	16.7M Colors
Active Area	698.4 x 392.85 mm
Size	32.0 inches
Panel Brightness	400 nits
View Angles	89,89,89,89
Touch / Glass	Projected Capacitive Multi Touch Screen
Environment	
Operating Humidity	10% to 90% (non-condensing)
Storage Temperature	-10~60°C
Operating Temperature	0~50°C
Certification	
Certification	CE, FCC
IO Ports	
USB Port	1 x USB for Touch Screen
Audio	2 x Speaker
Video	1 x VGA 1 x HDMI (Optional) 1 x DVI (Optional)
Mechanical	
Dimension	799 x 478 x 63.7 mm
Enclosure	Plastic
Mounting	VESA Mount
Cooling System	Fanless Design
Accessory	
Accessory	1 x VGA cable 1 x HDMI cable 100~240V AC to DC Adapter Power Cord Manual VESA screws(Varies by product)
Optional Accessory	Remote Controller (Optional,Varies by product)
Power	
Power Rating	12V DC input
Control	
Button	5 Keys: -, +, Power, Esc, Enter

DIMENSIONS UNIT:MM

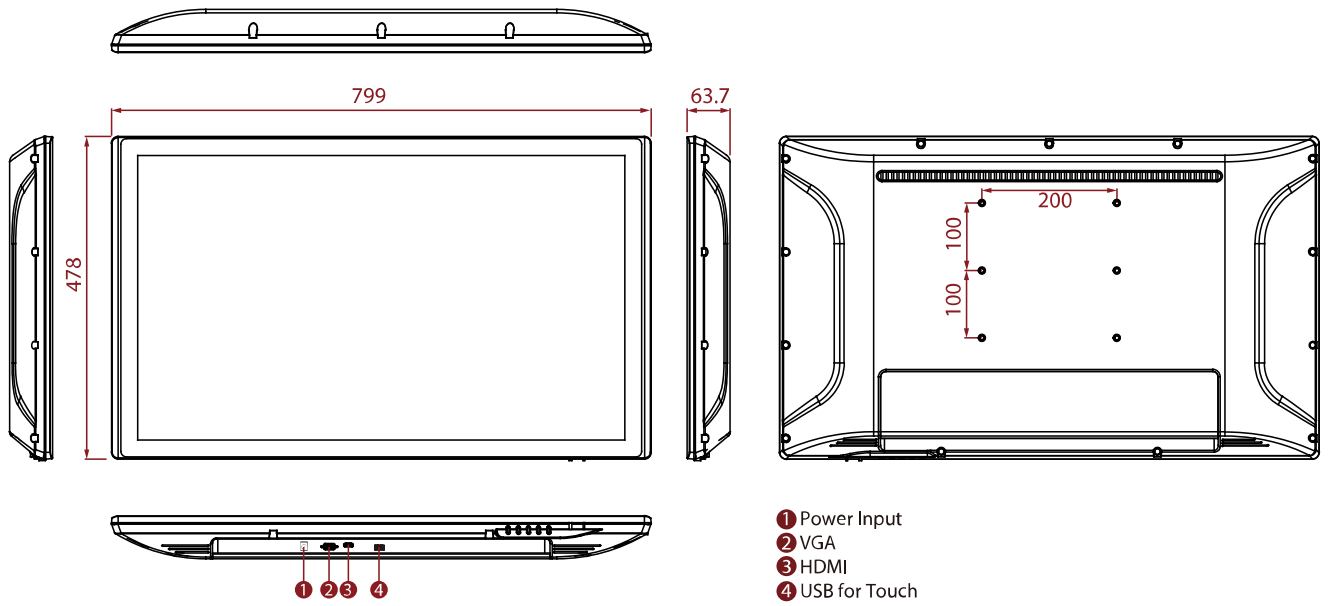

NOTE

1. The product shown in this datasheet is a standard model. For diagrams that contain customized or optional I/O, please contact the Winmate Sales Team for more information.