

R19L100-67FTP(HB)

19" G-WIN IP67 Series Display



KEY FEATURES

- Totally sealed Full IP67 aluminum compact housing design
- 19-inch 1280 x 1024 panel with Projected Capacitive touch screen
- -10 to 60°C wide operating temperature
- Fanless, streamlined enclosure for highly efficient heat dissipation
- Rugged Front Anti-Impact Design
- Front control membrane keys lockable by software
- Full IP67 male connectors with external female cables



SPECIFICATIONS

Display	
Resolution	1280x1024
Contrast Ratio	1000:1
Display Color	16.7M Colors
Active Area	376.32x301.06 mm
Optional function	High brightness Panel for sunlight readable (Optional)
Size	19 inches
Panel Brightness	350 nits 1000 nits(Optional)
View Angles	85,85,80,80
Touch / Glass	Projected Capacitive Multi Touch Screen Bonding With Panel
Mechanical	
Dimension	474 x 410 x 111 mm
Enclosure	Aluminum Housing
Cut out	462 x 386mm
Mounting	Panel mount VESA Mount
Cooling System	Fanless design
Environment	
Operating Humidity	10% to 90% (non-condensing)
Storage Temperature	-30~70°C
Vibration	MIL-STD-810G Method 514.6
Operating Temperature	-10~60°C
Shock	Ignore MIL-STD-810G Method 516.6 (Optional)
IP rating	IP67
Certification	
Certification	CE, FCC
IO Ports	
Power Input	1 x M12 waterproof connector for 9~36V DC
Serial Port	1 x M12 type connector for Touchscreen via RS232 signal (Optional)
Indicator	1 x LED Indicator for power 1 x LED Indicator for status
USB Port	1x M12 type connector for Touchscreen via USB signal
Video	1x M12 type connector for VGA input 1x M21 type connector for HDMI input (Optional)
Control	
Button	1 x Power Button 1 x Adjust up button 1 x Adjust down button

1 x ESC (Auto) button
1 x OK (Menu) button

Accessory

Accessory

External open wire Power cable with waterproof connector
External USB cable with waterproof connector
External VGA cable with waterproof connector
Waterproof caps
Driver CD & Manual
Mounting clips
VESA screws

Optional Accessory

100~240V AC to DC Adapter with power cord (Optional)
External COM cable with waterproof connector (Optional)
External HDMI cable with waterproof connector (Optional)

System Specification

DIMENSIONS UNIT:MM

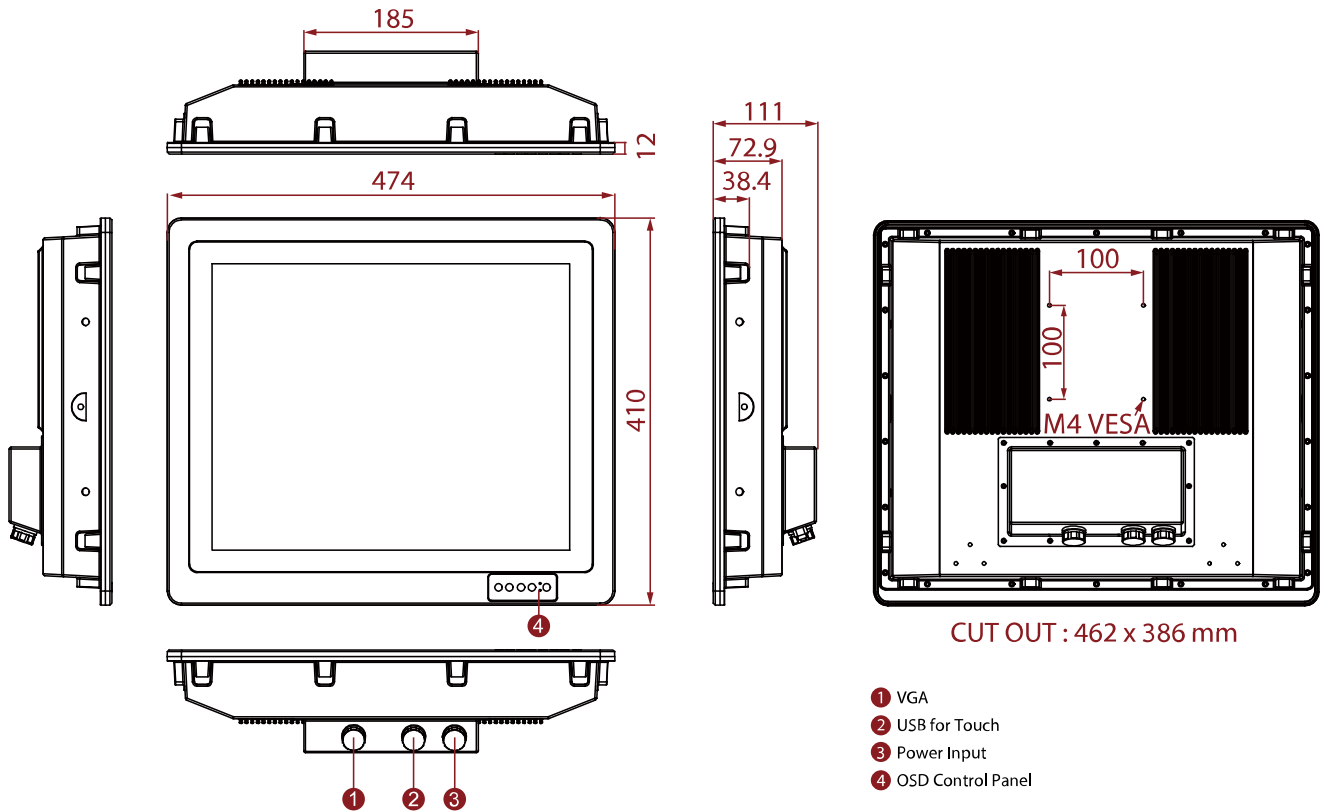

NOTE

1. This is a simplified drawing and some components are not marked in detail.
2. The product shown in this datasheet is a standard model. For diagrams that contain customized or optional I/O, please contact the Winmate Sales Team for more information.
3. All specifications are subject to change without prior notice.