

R15L100-67C3(HB)

15" G-WIN IP67 Series Display



KEY FEATURES

- High Quality 15" XGA Panel, 1024 x 768 resolution, 1000 nits
- Full IP67 Dust Water-proof Protection
- Aluminum Housing with Anti-Corrosion Treatments
- Built-in ambient Light sensor
- Optical Bonding with Anti Moisture Treatments
- Anti-Shock and Vibration Standard according to IEC60068-2-27
- 5 Wire Resistive Touchscreen / Anti-Reflective Protection Glass
- 9V ~ 36V DC Isolation Wide Range Power Input
- Compliance with EN50155



SPECIFICATIONS

Display			
Resolution	1024x768	Size	15 inches
Contrast Ratio	2000:1	Panel Brightness	300 nits
Display Color	16.2M Colors	View Angles	88,88,88,88
Active Area	304.1x228.1 mm	Touch / Glass	Resistive Touch Screen Bonding With Panel Protection Glass Without touch function (Optional)
Optional function	High brightness Panel for sunlight readable (Optional)		
Mechanical			
Dimension	398 x 308 x 58 mm	Mounting	VESA Mount Yoke Mount
Enclosure	Aluminum Housing	Cooling System	Fanless design
Environment			
Operating Humidity	10% to 90% (non-condensing)	Operating Temperature	-10~60°C
Storage Temperature	-30~70°C	Shock	Ignore MIL-STD-810G Method 516.6 (Optional)
Vibration	MIL-STD-810G Method 514.6	IP rating	IP67
Certification			
Certification	CE, FCC		
IO Ports			
Power Input	1 x M12 waterproof connector for 9~36V DC	USB Port	1x M12 type connector for Touchscreen via USB signal
Serial Port	1 x M12 type connector for Touchscreen via RS232 signal (Optional)	Video	1x M12 type connector for VGA input 1x M21 type connector for HDMI input (Optional)
Indicator	1 x LED Indicator for power 1 x LED Indicator for status		
Control			
Button	1 x Power Button 1 x Adjust up button 1 x Adjust down button 1 x ESC (Auto) button		

1 x OK (Menu) button

Accessory

Accessory

External open wire Power cable with waterproof connector
External USB cable with waterproof connector
External VGA cable with waterproof connector
Waterproof caps
Driver CD & Manual
VESA screws

Optional Accessory

Yoke mount stand (Optional)
100~240V AC to DC Adapter with power cord (Optional)
External COM cable with waterproof connector (Optional)
External HDMI cable with waterproof connector (Optional)

System Specification

DIMENSIONS UNIT:MM

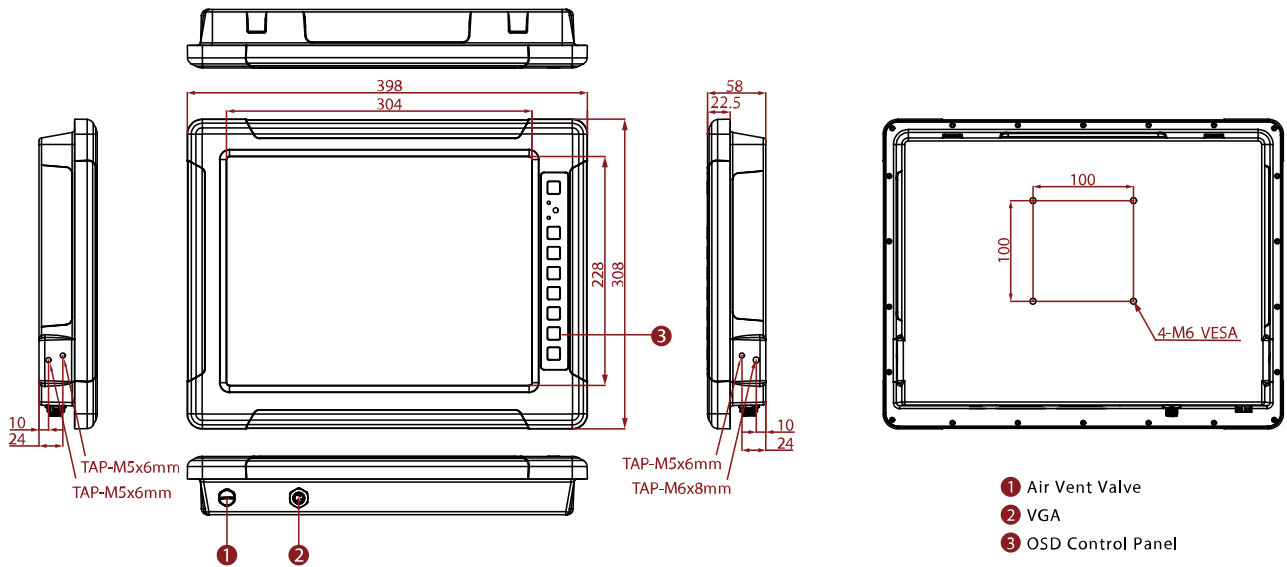

NOTE

1. This is a simplified drawing and some components are not marked in detail.
2. The product shown in this datasheet is a standard model. For diagrams that contain customized or optional I/O, please contact the Winmate Sales Team for more information.
3. All specifications are subject to change without prior notice.