

# OD3-2000MOD2-BLK

**Omni Directional Antenna (Foam Filled)  
3 dBi with Mounting Kit, 1710-2170 MHz**

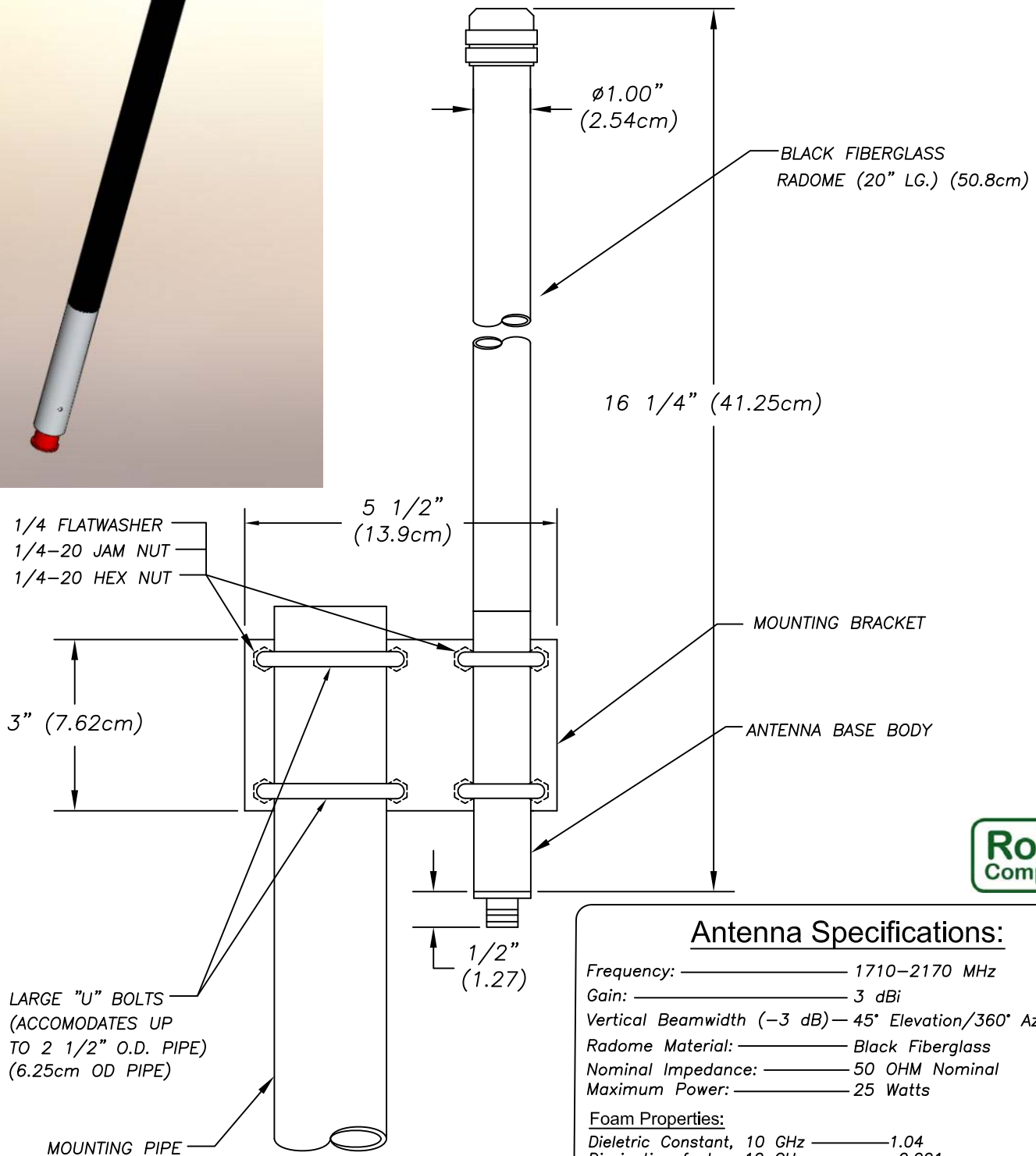

## Antenna Specifications:

Frequency: \_\_\_\_\_ 1710-2170 MHz  
Gain: \_\_\_\_\_ 3 dBi  
Vertical Beamwidth (-3 dB) — 45° Elevation/360° Azimuth  
Radome Material: \_\_\_\_\_ Black Fiberglass  
Nominal Impedance: \_\_\_\_\_ 50 OHM Nominal  
Maximum Power: \_\_\_\_\_ 25 Watts

### Foam Properties:

Dielectric Constant, 10 GHz \_\_\_\_\_ 1.04  
Dissipation factor, 10 GHz \_\_\_\_\_ 0.001

Connector: \_\_\_\_\_ "N" Female  
Lightening Protection: \_\_\_\_\_ DC Shorted External Recommended  
Mount: (Mount Kit included) — Mounts up to 2 1/2" OD Pipe  
Weight (with mount): \_\_\_\_\_ 2.5 lbs. (1.13kg)  
Temperature: \_\_\_\_\_ -40C to +80C  
Wind Survivability: \_\_\_\_\_ 125 mph minimum  
\_\_\_\_\_ 125 mph with 1/2" radial ice  
Shock & Vibration: \_\_\_\_\_ IEEE1478, EN 61373, MIL-810G, TIA 329.2-C  
Dust/Water Ingress: \_\_\_\_\_ IP67

Specifications subject to change without notice

RP 5/2/17 A

# MobileMark

antenna solutions

US OFFICE & HEADQUARTERS: 1140 W THORNDALE AVE, ITASCA, IL 60143  
TEL: (847) 671-6690 \* FAX (847) 250-5120

UK OFFICE: 8 MIRAS BUS PARK, KEYS PARK ROAD, HEDNESFORD WS12 2FS, UK.  
UK TEL: (+44) 1543-459555 FAX (+44) 1543-459545

VISIT OUR WEBSITE AT WWW.MOBILEMARK.COM