

M1227HCT-A2-SMA

RUGGED L1/L2 GPS GLONASS ACTIVE ANTENNA

Ordering Part #: 100-00004-02

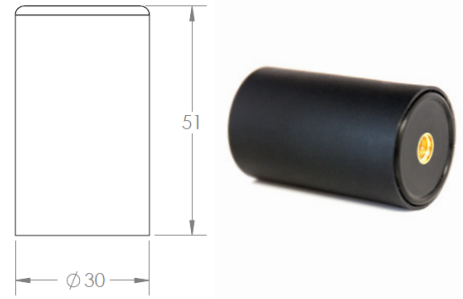

Description

The M1227HCT-A2-SMA is Maxtena's latest high performance Active rugged antenna designed for L1/L2 GPS and GLONASS bands. The antenna is designed for applications requiring greater accuracy than what L1 only antennas can provide. The antenna is built on proprietary Maxtena Helicore® technology. This technology provides exceptional pattern control, polarization purity and high efficiency in a very compact form factor. It is a screw-on design, featuring an integrated SMA connector. This antenna has superior filtering performance and is rated for 50 V/m out of band interference. The product is ideal for applications requiring minimal integration effort or for retrofitting existing products. The antenna is equipped with an O-ring and its rugged assembly is rated IP-67.

Electrical Specifications

Parameter	Design Specifications
Frequency	1217-1250 MHz (L2) 1565-1610 MHz (L1)
Polarization	RHCP
Passive peak gain	2 dBic @ 1227 MHz (typical) 2 dBic @ 1575 MHz (typical)
Total gain	30 dBic @ 1227 MHz (typical) 28 dBic @ 1575 MHz (typical) 28 dBic @ 1602 MHz (typical)
Out-of-band rejection	>50 dB
Current drain	25 mA (typical)
Voltage	3-12 V
Noise figure	1.5 dB (typical)
RF interference rating	50 V/m out of band
Operating temp.	from -40°C to 85°C

Mechanical Specifications

dimensions are in mm

Features

- L1/L2 GPS-GLONASS bands
- Rugged IP-67 rating
- Superior out-of-band rejection
- 50 V/m jamming resistant
- Very low noise figure
- SMA mount
- Ground plane independent
- GIS & RTK applications
- Ultra light weight - 24 grams (typical)

Applications

- Precision navigation
- Precision timing
- Military & security
- Asset tracking
- Oil & gas industries
- Navigation devices
- Mining equipment
- LBS & M2M applications
- Handheld devices
- Law enforcement

L1 Band Typical Performance

Parameter	Design Specifications
Total peak gain	28 dBic
Axial Ratio	0.5 dB (typical) / 1 dB (max)
VSWR	<1.5

L2 Band Typical Performance

Parameter	Design Specifications
Total peak gain	30 dBic
Axial Ratio	0.5 dB (typical) / 1 dB (max)
VSWR	<1.5

L1 Band Frequency Response

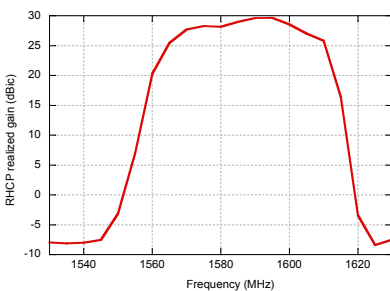

L1 Gain (dBic)

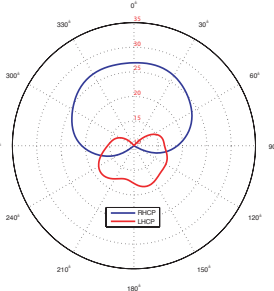

L2 Band Frequency Response

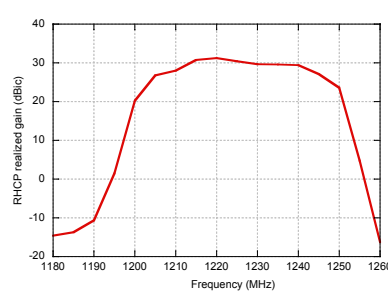

L2 Gain (dBic)

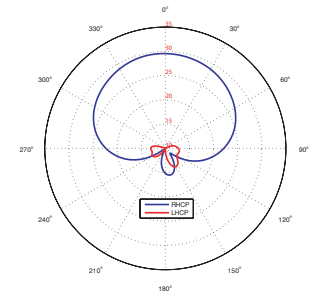

DRAWING REVISION HISTORY			
REV	DESCRIPTION	DATE	BY
A	INITIAL RELEASE	2020-12-08	QZ

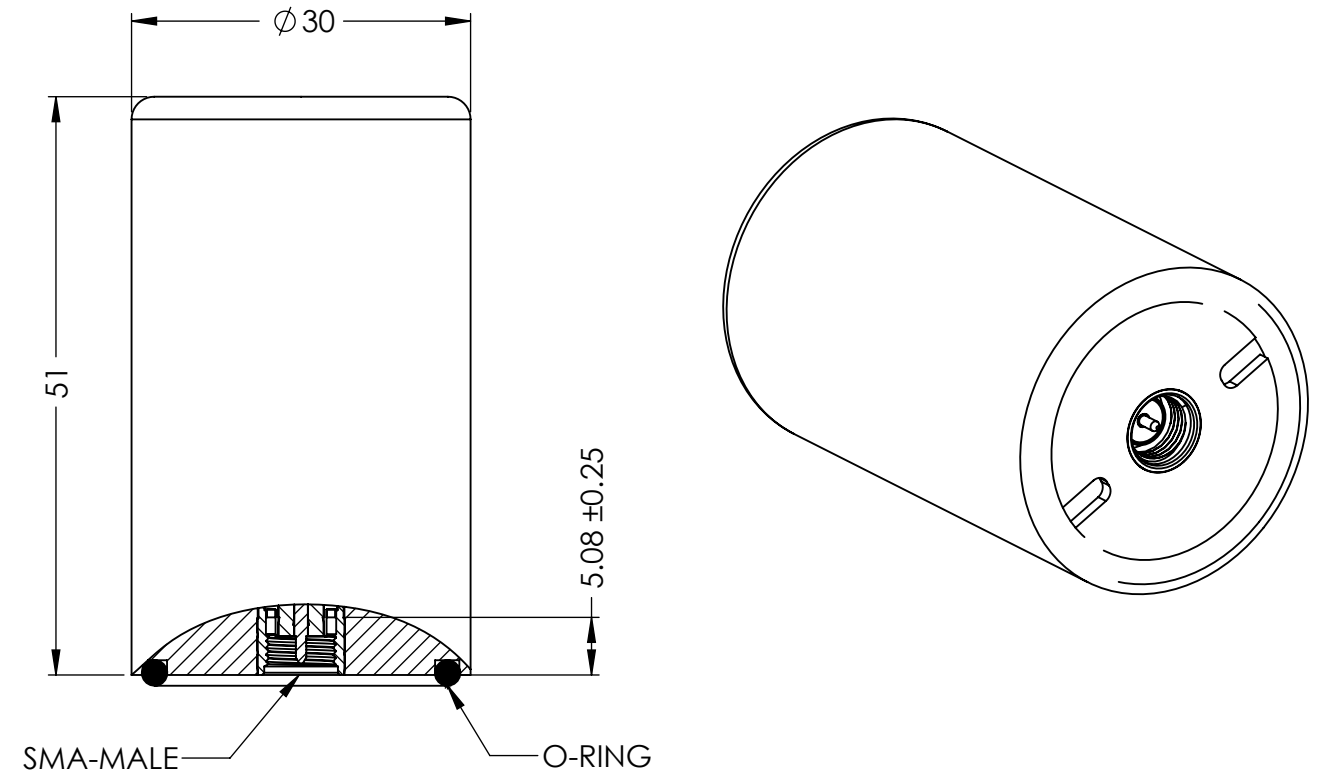

NOTES:

1. CONNECTOR TYPE: SMA-MALE.
2. HOUSING MATERIA: ABS/PC.
3. COLAR: BLACK.
4. DUST AND WATER-RESISTANCE: IP67.
5. RECOMMEND A 4.9MM MOUNTING HEIGHT FOR MOUNTING INTERFACE SEALING AND ELECTRICAL CONNECTION. ASSEMBLY TORQUE SHALL BE NO MORE THAN 8 IN*LB.

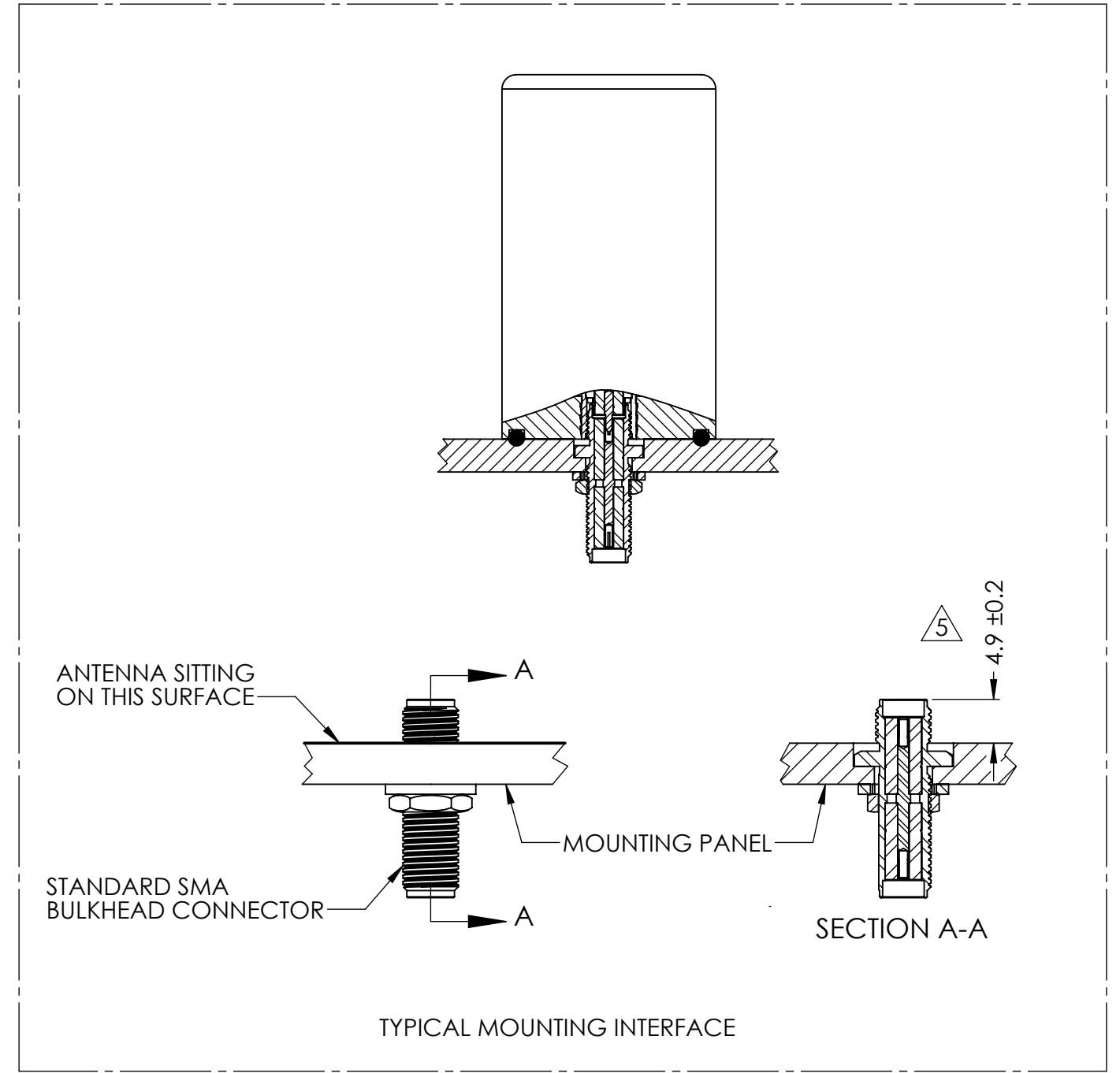

ITEM 100-00004-02 REVISION HISTORY			
REV	DESCRIPTION	DATE	BY
A	INITIAL RELEASE	2106-05-13	SMS
B	ADD FOAM RING, CHANGE ADHESIVE & REPLACE REGULAR BASE AND HOUSING TO THREADED BASE AND HOUSING	2020-11-25	MP

PROPRIETARY AND CONFIDENTIAL

THE INFORMATION CONTAINED IN THIS DRAWING IS THE SOLE PROPERTY OF MAXTENA, INC. ANY REPRODUCTION IN PART OR AS A WHOLE WITHOUT THE WRITTEN PERMISSION OF MAXTENA, INC IS PROHIBITED.

UNLESS OTHERWISE SPECIFIED:	NAME	DATE
DIMENSIONS ARE IN MM	DRAWN	QZ 2020-12-08
TOLERANCES:	CHECKED	ZX 2020-12-14
FRACTIONAL ±	ENG APPR.	NPC 2020-12-14
ANGULAR: MACH ± .5° BEND ±	MFG APPR.	
INTEGER ± 2	Q.A.	
ONE PLACE DECIMAL ± 1.0		
TWO PLACE DECIMAL ± 0.50		
INTERPRET GEOMETRIC TOLERANCING PER:		
	CAD MAINTAINED. CHANGES SHALL BE INCORPORATED BY THE DESIGN ACTIVITY.	
DO NOT SCALE DRAWING		

MAXTENA, INC		
TITLE: 100-00004-02 M1227HCT-A2-SMA		
SIZE	DWG. NO.	REV
B	117-00373-01	A
CAGE CODE: 5KQH7	SCALE: NONE	SHEET 1 OF 1