

Helix Antenna HX-CUX615A

Harxon HX-CUX615A is the housed version of HX-CUX012A, high performance option for UAV as always. It offers superior satellite signal tracking, including GPS, GLONASS, GALILEO, Beidou, QZSS, SBAS, IRNSS as well as L-Band correction service. It provides excellent axial ratios, enables excellent multipath mitigation and a very precise phase center. With low profile design, it is easy to be integrated, ideal for various UAV applications such as aerial photography, remote sensing, infrastructure inspection, traffic control and public security.



LOW PROFILE, EASY TO BE INTEGRATED

HX-CUX615A is designed with super low profile (33mm) and weighs only 43g, ideal to be integrated into UAVs, surveying and monitoring devices. It reduces the overall weight of applications and meets the strict demands of low profile.

HIGH PHASE CENTER STABILITY AND CONSISTENT PERFORMANCE

The HX-CUX615A antenna features multi-point feeding technology that ensures a high phase center stability with centimeter level accuracy. It has a high peak gain of 3.0 dBi and excellent axial ratios, enabling excellent multipath mitigation and a very precise phase center.

STRONG ANTI-INTERFERENCE PERFORMANCE

HX-CUX615A optimizes circuit layout and equips a robust pre-filtered LNA that features an excellent out-of-band interference rejection performance and restrains possible unwanted electromagnetic interference, providing reliable GNSS signals for easy integration into positioning solutions.

ADVANCED PATENTED D-QHA TECHNOLOGY

The HX-CUX615A antenna adopts patented D-QHA technology for stable performance of wide-angle circular polarization (WACP), which ensures exceptional low elevation satellite tracking while maintaining high gain and providing reliable signal tracking. This consistent performance makes it ideal option for UAVs even under challenging environments.

KEY FEATURES

- Comprehensive GNSS support: GPS, GLONASS, Galileo, Beidou, QZSS, SBAS as well as L-Band correction service
- Excellent RHCP signal reception and signal-to-noise ratio
- Centimeter phase center repeatability, high gain at low elevation
- Improved signal filtering and excellent multipath rejection
- Super low profile (33mm) , easy to be integrated

Helix Antenna HX-CUX615A

PERFORMANCE

Signal Received	
GPS	L1/L2/L5
BDS	B1/B2/B3
GLONASS	L1/L2/L3
GALILEO	E1/E5a/E5b/E6
QZSS	L1/L2/L5/L6
SBAS	L1/L5
L-Band	
Nominal Impedance	50Ω
Polarization	RHCP
Axial Ratio	≤3.0dB
Azimuth Coverage	360°
Output VSWR	≤2
Gain RHCP (maximum)	1166~1278 2.8dBi 1559~1612 3.3dBi L-Band 1.5dBi

LNA

LNA Gain	33±2dB
Noise Figure	≤2dB
Output VSWR	≤2.0
Operation Voltage	3.3~12VDC
Operation Current	≤35mA
Passband Ripple	±2dB

ENVIRONMENTAL

Operating Temperature	-40°C~+70°C
Storage Temperature	-55°C~+70°C
Humidity	95% Non-condensing

MECHANICAL

Dimensions	φ50*33mm
Connector	SMA Male
Weight	43g
Mounting	3* M2.5 Screws

en.harxon.com

sales@harxon.com

9/F, Block B, Building D3, TCL International
E City, NO.1001 Zhongshanyuan Road,
Nanshan District, Shenzhen, China

Tel: +86-755-26989948

Fax: +86-755-26989994

Version 1 Specifications subject to change without notice.
©2023 Harxon Corporation. All rights reserved.
Printed in China
September 2023

Structure & Phase Center Drawing (mm)

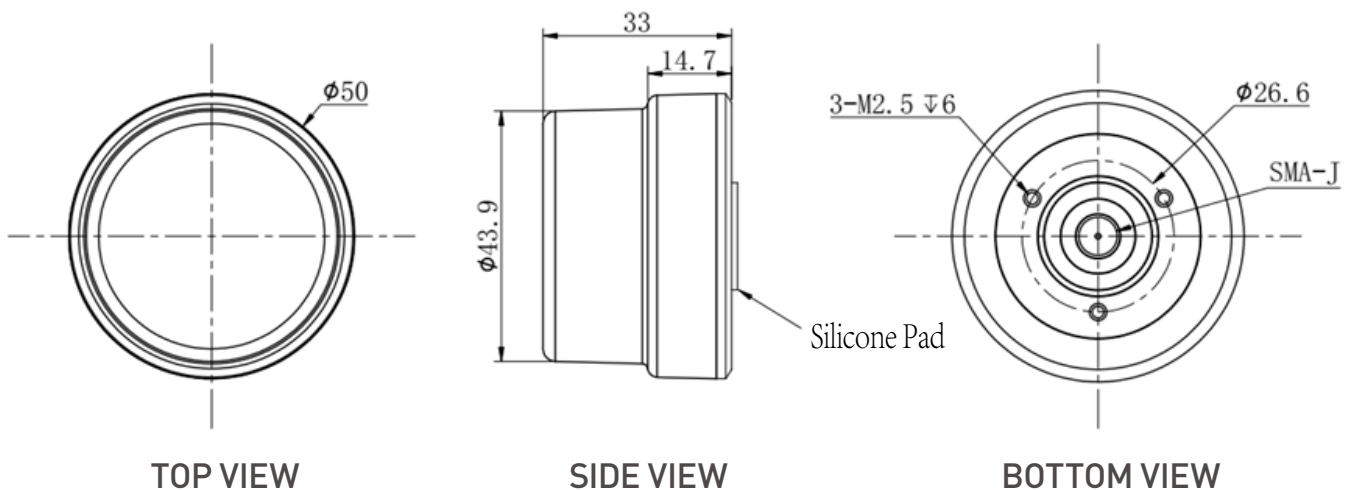

Undeclared Tolerance: ±0.3mm

Installation Instructions

Usually, the antenna can be installed by using 3 M2.5 screws with a length of $\leq 6\text{mm} + T$ (T refers to the thickness of the mounting plate, unit: mm) through the bottom to lock it upward. The screw locking torque range is 3~3.5/kgf.cm.