

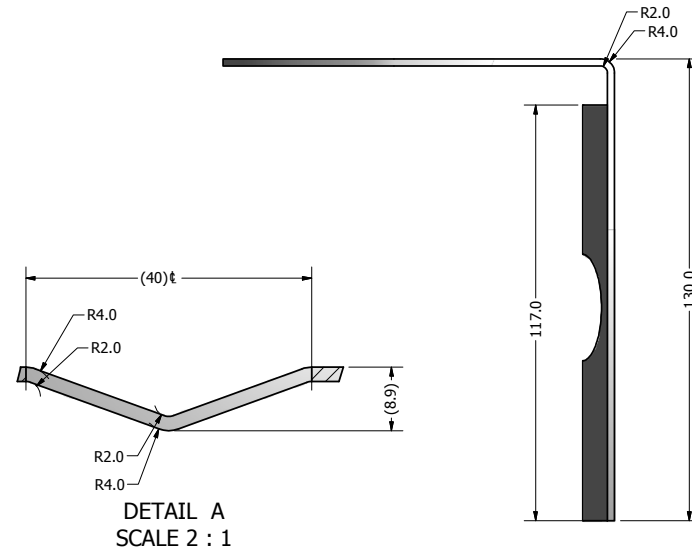

REVISION HISTORY			
REV	DESCRIPTION	DATE	APPROVED
A	RELEASE TO PRODUCTION [C08219]	21FEB12	FXG

NOTES: UNLESS OTHERWISE SPECIFIED

1. INTERPRET DRAWING PER ANSI/ASME Y14.5
2. MATERIAL: 304ss
3. FINISH: PASSIVATE PER ASTM A-967 CITRIC 2 OR NITRIC 2.
4. ALL MATERIALS SHALL BE ROHS COMPLIANT.
5. PARTS SHALL BE PACKAGED TO PREVENT DAMAGE IN SHIPMENT AND HANDLING.
6. AN [X] DIM IDENTIFIES A KEY CHARACTERISTIC AND MAY REQUIRE Cpk STUDY AS OUTLINED IN PCTEL CQR (COMPONENT QUALIFICATION REQUIREMENTS) RECORD. WHERE NO CQR EXISTS, A COMPLETE 1ST ARTICLE LAYOUT SHALL BE SUBMITTED WITH INITIAL ORDER. A (REF) DIMENSION IS FOR INFORMATION PURPOSES ONLY AND NO TOLERANCE IS IMPLIED.

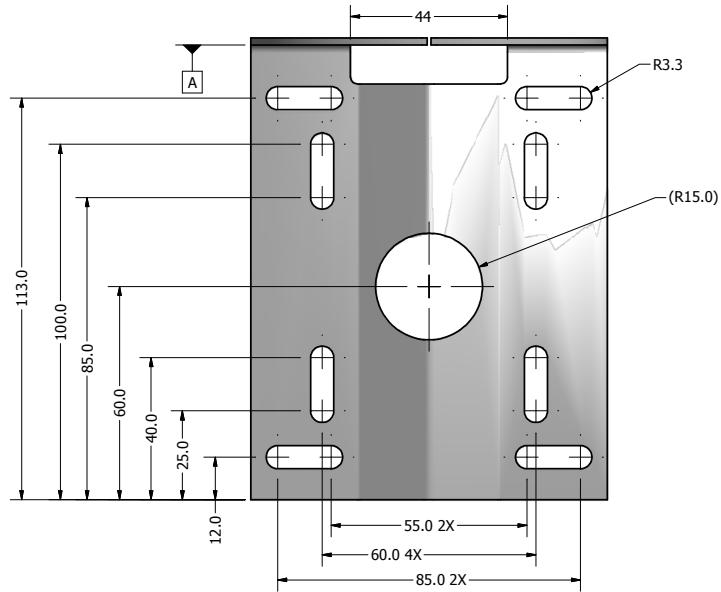
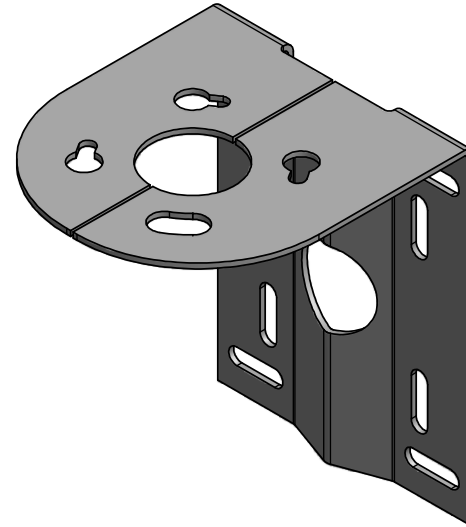
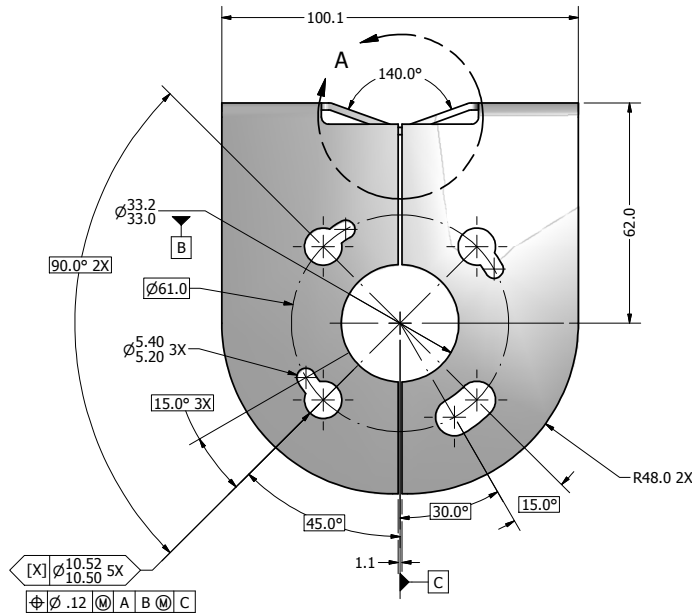

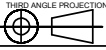
UNLESS OTHERWISE SPECIFIED, DIMENSIONS ARE IN MILLIMETERS. FOR TOLERANCES NOT SPECIFIED USE: (X mm ± 0.3 mm), (ØX mm ± 0.3 mm), (XX mm ± .13 mm), ANGULAR ± 1°	DRAWN	DATE	 PCTEL, INC. BROADBAND TECHNOLOGY GROUP 471 BRIGHTON DRIVE BLOOMINGDALE, IL 60108 PH. 630-372-6800 FAX. 630-372-8077
	FXG	8/20/2009	
 THIRD ANGLE PROJECTION	CHECKED	DATE	DESCRIPTION BRACKET, L, TIMING, MEDIUM DUTY, 304SS
	APPROVED	DATE	
PROPRIETARY DATA THE INFORMATION CONTAINED IN THIS DOCUMENT IS OF A PROPRIETARY NATURE. IT MAY NOT BE USED OR REPRODUCED WITHOUT EXPRESS WRITTEN PERMISSION OF PCTEL INC., BLOOMINGDALE, IL 60108	MATERIAL	DATE	DRAWING NO. 26-2702-1
	SEE NOTE 2	DATE	
	FINISH	DATE	SIZE A2
	SEE NOTE 3	DATE	SCALE 1:1
		DATE	SHEET 1 OF 2